

MODEL WOPS USED OIL PUMP STATION

FRONTLINE™
international

PROJECT _____
QUANTITY _____
APPROVAL _____
DATE _____

SPECIFICATIONS

Solution for transferring fats, oils, and grease to a remote containment tank. Ideal for extracting fryer oil when fryer lacks a built-in filtration pump.

- **Installation Flexibility:** Mounted on a wall, floor, or even in the ceiling near the FOG generating equipment.
- **Effective Oil Transfer:** The system features a stainless-steel nozzle connected to a high-temperature, spring-loaded suction hose. This enables clean and thorough transfer of used shortening or fats from the fryer vat, convection oven, rotisserie and more.
- **Debris Protection:** A permanent strainer is integrated at the end of the suction nozzle to safeguard the pump and plumbing from debris.
- **Comprehensive Control:** Optional, user-friendly control panel, conveniently located near the pump station, allows for seamless pump operation, monitors the containment tank's condition, displays the oil level, and manages the overflow protection system to prevent spills and ensure safe operation.



STANDARD FEATURES

- Quick-disconnect fittings for easy maintenance
- Seamless construction allows for effortless cleaning

AGENCY APPROVAL OPTIONS

- UL 197
- UL 1889
- CE
- UKCA

POWER CORD CONFIGURATION Select one of the following.

- NA (North America):** Standard: NEMA 5-15 Voltage: 120V Frequency: 60Hz
- EU (European Union):** Standard: CEE 7/7 (Type F) Voltage: 230V Frequency: 50Hz
- UK (United Kingdom):** Standard: BS 1363 Voltage: 230V Frequency: 50Hz
- AU (Australia):** Standard: AS/NZS 3112 Voltage: 230V Frequency: 50Hz

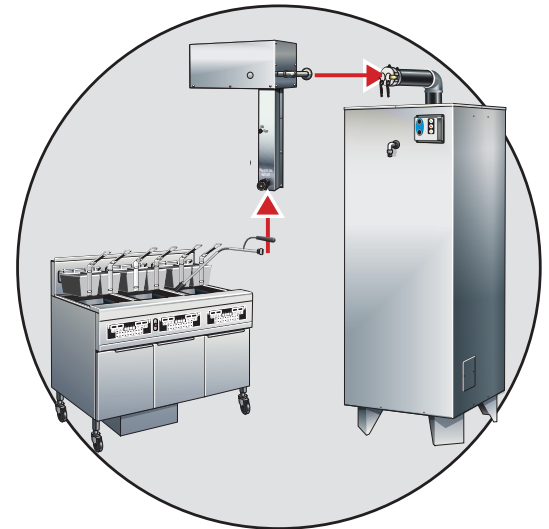

The WOPS System is an ideal way to move fats, oils, and grease from food service equipment to the containment tank when there is no built-in filtration pump.

Frontline International, Inc.

187 Ascot Parkway • Cuyahoga Falls, Ohio 44223 • 330-861-1100 • 877-776-1100 • frontlineii.com • Fax: 330-861-1105 • info@frontlineii.com

MODEL WOPS USED OIL PUMP STATION

FRONTLINE™
international

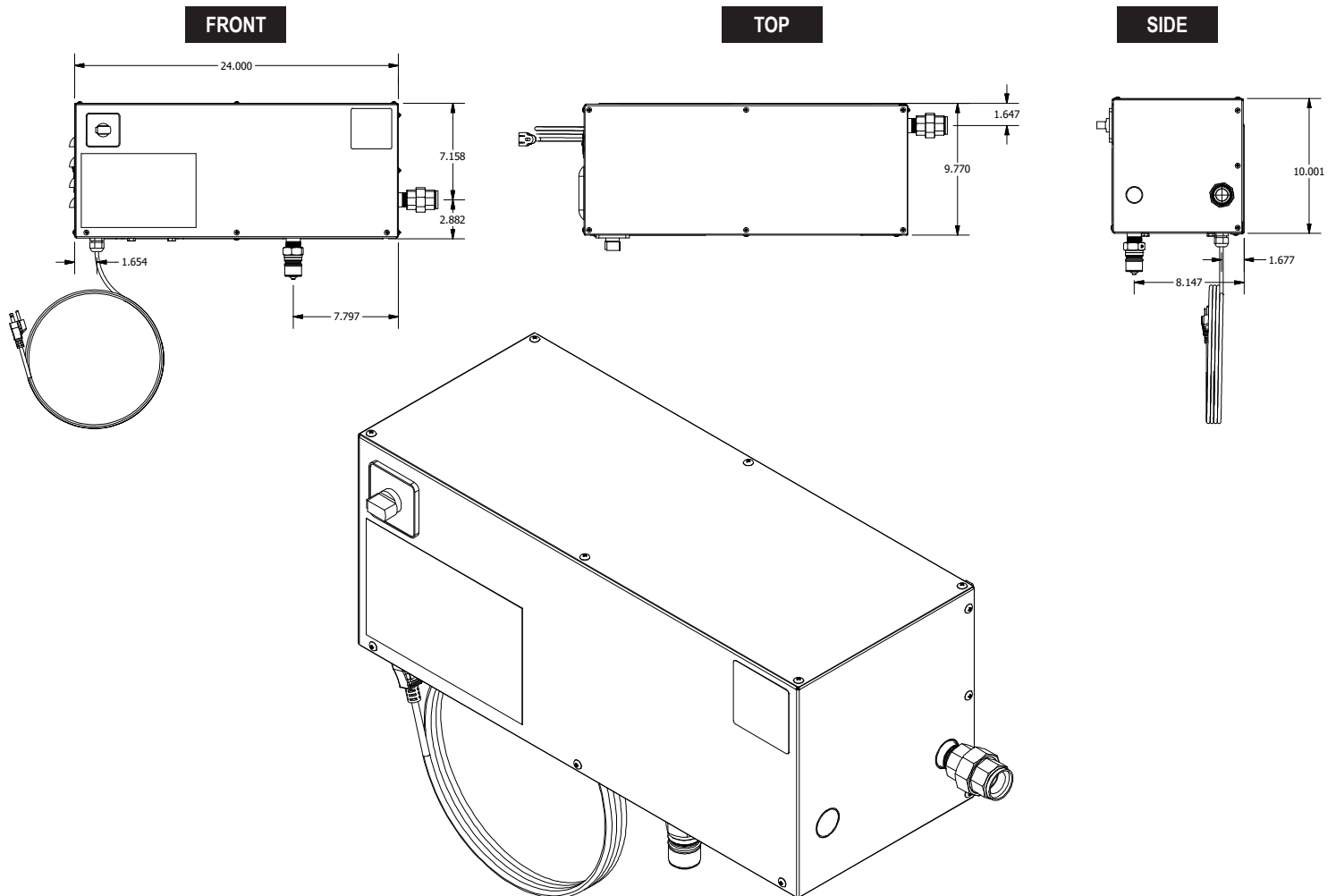

MODEL	PUMP SPEED	SHIPPING WEIGHT	MOUNTING SPACE REQUIREMENTS	POWER REQUIREMENTS
WOPS	8 gal/per minute	100 lbs. (45.3 kg)	24 in. w x 10 in. h x 10 in. d (609.6 mm x 254 mm x 254 mm)	LV: 110 V 15 A, 60 Hz HV: 250 V 3.5 A, 50/60 Hz

* Information is approximate and may vary at time of shipment due to options/add-ons per customer request.

IMPORTANT

- The appliance is not to be used by persons (including children) with reduced physical, sensory or mental capabilities, or lack of experience and knowledge, unless they have been given supervision or instruction.
- Children should be supervised to ensure that they do not play with the appliance.
- If the supply cord is damaged, it must be replaced by the manufacturer, its service agent or similarly qualified persons in order to avoid a hazard.
- Not intended to be operated by means of an external timer or a separate remote-control system.
- This appliance is intended to be used in commercial kitchen applications.

Frontline International, Inc.

187 Ascot Parkway • Cuyahoga Falls, Ohio 44223 • 330-861-1100 • 877-776-1100 • frontlineii.com • Fax: 330-861-1105 • info@frontlineii.com