

# MODEL 16SS

## TRANSPORT CADDY

HOLDS 120 lb/16 gal (54.4 kg/60.5 l)

**FRONTLINE™**  
international

PROJECT \_\_\_\_\_

QUANTITY \_\_\_\_\_

APPROVAL \_\_\_\_\_

DATE \_\_\_\_\_

### SPECIFICATIONS

Frontline International stainless steel transport caddies are the most economical method of transporting grill grease and cooking oil to the containment tank.

### FILTER UPGRADE KITS

- FILTER-KIT-FP** Caddy-To-Filtration System Upgrade Kit, Paper Media Filter
- FILTER-KIT-FS** Caddy-To-Filtration System Upgrade Kit, Stainless Steel Media Filter

### AGENCY APPROVAL OPTIONS

- UL 197**
- UL 1889**
- CE**
- UKCA**

### POWER CORD CONFIGURATION Select one of the following.

- NA (North America):** Standard: NEMA 5-15 Voltage: 120V Frequency: 60Hz
- EU (European Union):** Standard: CEE 7/7 (Type F) Voltage: 230V Frequency: 50Hz
- UK (United Kingdom):** Standard: BS 1363 Voltage: 230V Frequency: 50Hz
- AU (Australia):** Standard: AS/NZS 3112 Voltage: 230V Frequency: 50Hz

### OPTIONAL CONFIGURATIONS

- REVERSIBLE PUMP**
- HEATER**
- 5" (12.7CM) CASTERS**

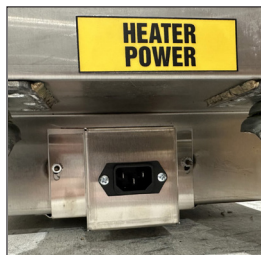

### STANDARD FEATURES

- 100% heavy stainless steel construction
- Seamless integration with Frontline International containment systems
- Smooth rolling heavy-duty, non-mark casters
- Swivel front casters with brakes
- Extra large "crumb catcher" basket
- Power switch and "break away" power cord
- Removable handle
- Lock-in-place safety cover
- Easy, quick-disconnect fittings
- High-temperature hose
- Specially designed 5-gallon (19 l) per minute pump



Frontline International, Inc.

187 Ascot Parkway • Cuyahoga Falls, Ohio 44223 • 330-861-1100 • 877-776-1100 • [frontlineii.com](http://frontlineii.com) • Fax: 330-861-1105 • [info@frontlineii.com](mailto:info@frontlineii.com)

# MODEL 16SS

## TRANSPORT CADDY

HOLDS 120 lb/16 gal (54.4 kg/60.5 l)

**FRONTLINE™**  
international

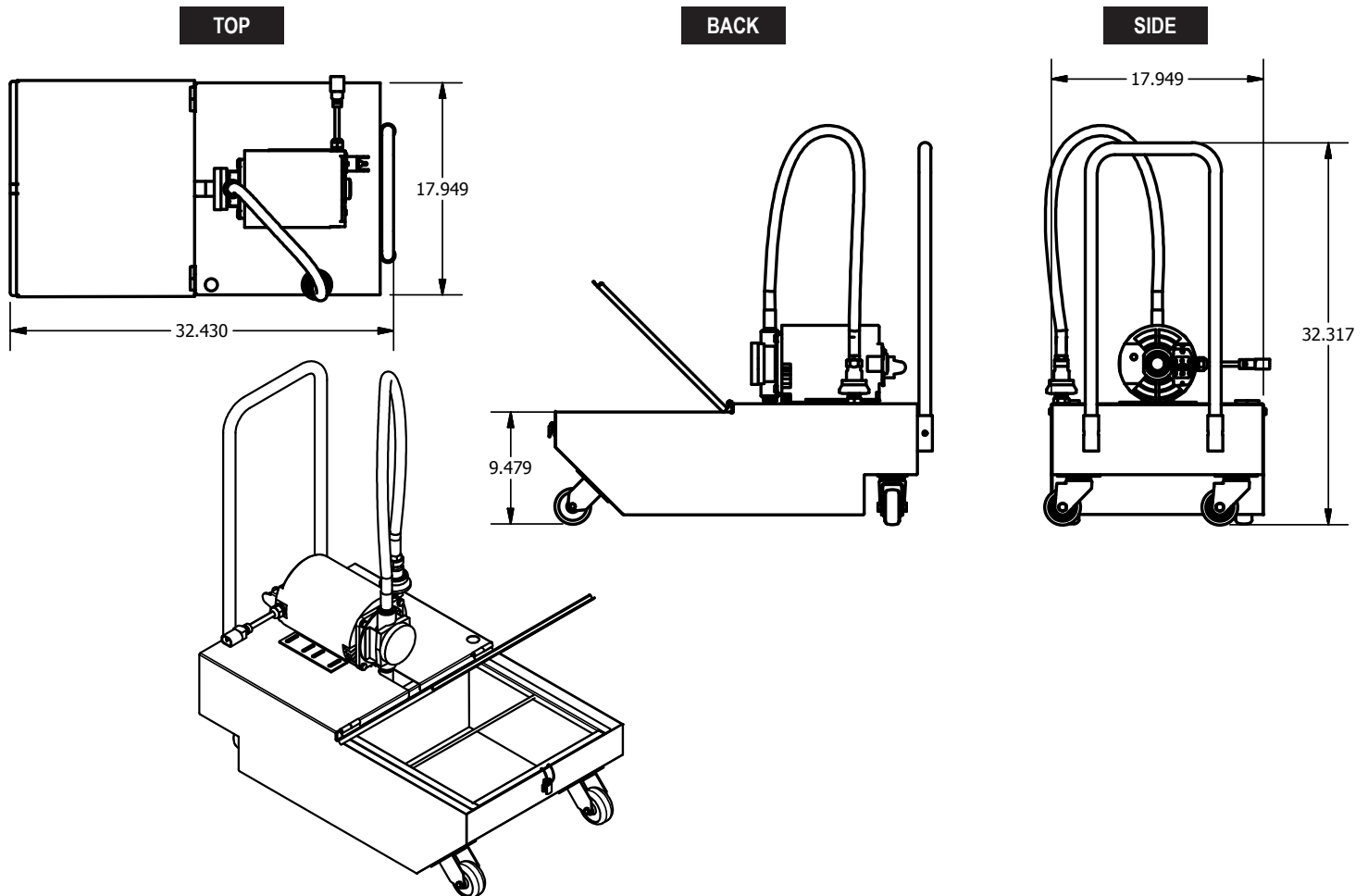

MODEL	CAPACITY	SHIPPING WEIGHT	INSTALLATION SPACE REQUIREMENTS	POWER REQUIREMENTS
16SS	120 lb /16 gal (54.4 kg/60.5 l)	165 lbs (75 kg)	32 in. l, 18 in. w, 9.5 in. h (812 mm x 457 mm x 241.3 mm)	LV: 110 V 15 A, 60 Hz HV: 250 V 3.5 A, 50/60 Hz

\* Information is approximate and may vary at time of shipment due to options/add-ons per customer request.

### IMPORTANT

- The appliance is not to be used by persons (including children) with reduced physical, sensory or mental capabilities, or lack of experience and knowledge, unless they have been given supervision or instruction.
- Children should be supervised to ensure that they do not play with the appliance.
- If the supply cord is damaged, it must be replaced by the manufacturer, its service agent or similarly qualified persons in order to avoid a hazard.
- Not intended to be operated by means of an external timer or a separate remote-control system.
- This appliance is intended to be used in commercial kitchen applications.

Frontline International, Inc.

187 Ascot Parkway • Cuyahoga Falls, Ohio 44223 • 330-861-1100 • 877-776-1100 • [frontlineii.com](http://frontlineii.com) • Fax: 330-861-1105 • [info@frontlineii.com](mailto:info@frontlineii.com)