

MODEL RACKVP20

EZ OIL VERSAPOUR™ FRESH OIL DISPENSING STATION

HOLDS 637.5 lb/85 gal (289.2 kg/322 l)

FRONTLINE™
international

PROJECT _____

QUANTITY _____

APPROVAL _____

DATE _____

SPECIFICATIONS

Designed for truly versatile operation, EZ Oil VersaPour works seamlessly with standard boxed oils or jugs, but can also be used with tallow or other semi-solid fats. Operators have freedom to choose whichever frying material best fits their menu, budget, or performance needs. Can be used with standard cooking oil or, when paired with optional warming or melting accessories, tallow or other semi-solid fats.

STANDARD FEATURES

- Heavy stainless steel construction
- Control panel with alarm
- Easy to access and service components

AGENCY APPROVAL OPTIONS

- UL 197
- UL 1889
- CE
- UKCA

POWER CORD CONFIGURATION Select one of the following.

- NA (North America):** Standard: NEMA 5-15 Voltage: 120V Frequency: 60Hz
- EU (European Union):** Standard: CEE 7/7 (Type F) Voltage: 230V Frequency: 50Hz
- UK (United Kingdom):** Standard: BS 1363 Voltage: 230V Frequency: 50Hz
- AU (Australia):** Standard: AS/NZS 3112 Voltage: 230V Frequency: 50Hz

OPTIONAL CONFIGURATIONS

- WARMING ACCESSORY
- MELTING ACCESSORY



MODEL RACKVP20

FRONTLINE™
international

EZ OIL VERSAPOUR™ FRESH OIL DISPENSING STATION

HOLDS 637.5 lb/85 gal (289.2 kg/322 l)

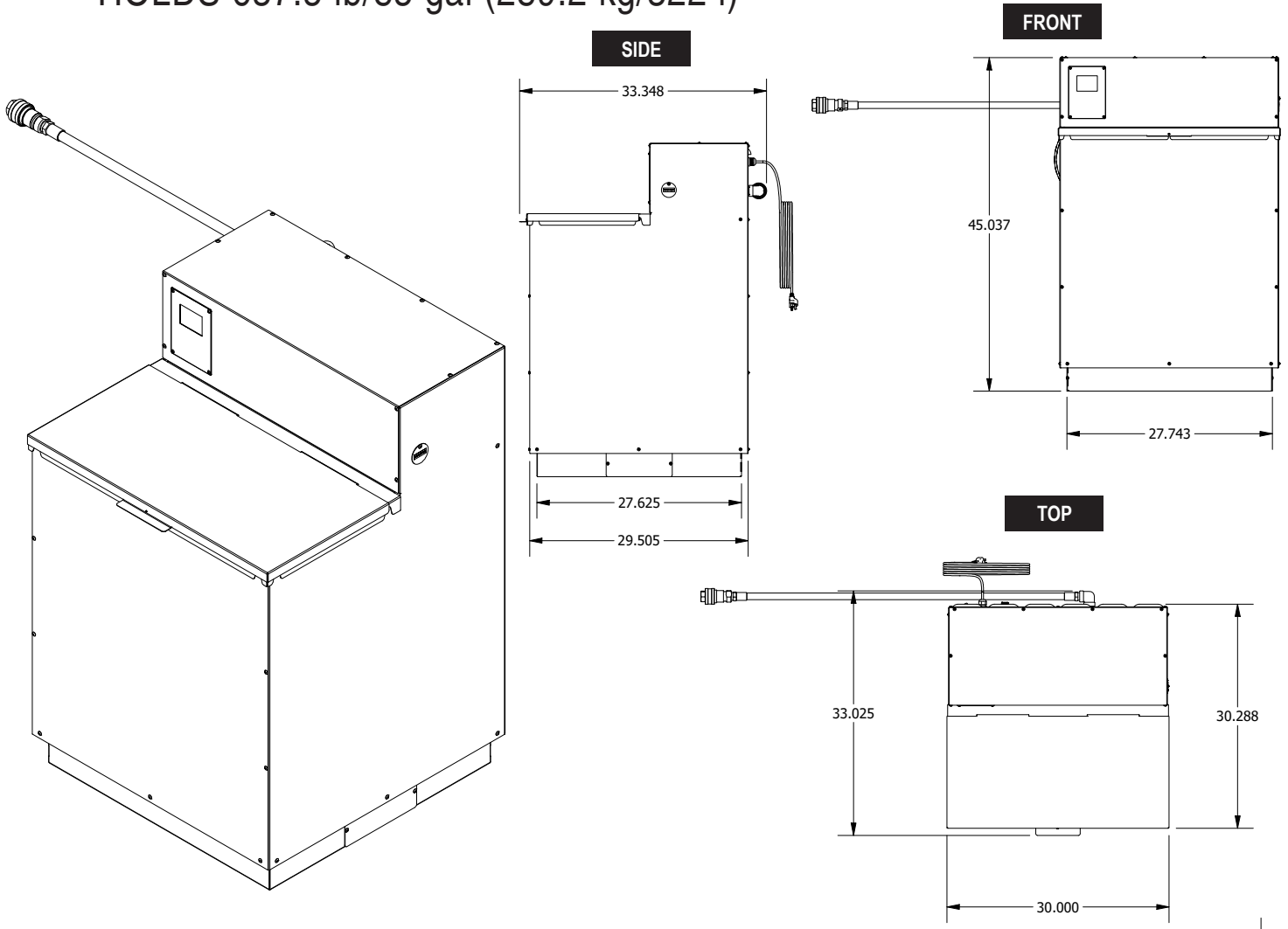

MODEL	CAPACITY	SHIPPING WEIGHT	MOUNTING SPACE REQUIREMENTS	POWER REQUIREMENTS
RACK20	637.5 lb/85 gal (289.2 kg/322 l)	180 lb (82 kg)	33 in. l x 30 in. w x 45 in. h (838 mm x 762 mm x 1143 mm)	LV: 110 V 15 A, 60 Hz HV: 250 V 3.5 A, 50/60 Hz

* Information is approximate and may vary at time of shipment due to options/add-ons per customer request.

IMPORTANT

- The appliance is not to be used by persons (including children) with reduced physical, sensory or mental capabilities, or lack of experience and knowledge, unless they have been given supervision or instruction.
- Children should be supervised to ensure that they do not play with the appliance.
- If the supply cord is damaged, it must be replaced by the manufacturer, its service agent or similarly qualified persons in order to avoid a hazard.
- Not intended to be operated by means of an external timer or a separate remote-control system.
- This appliance is intended to be used in commercial kitchen applications.

Frontline International, Inc.

187 Ascot Parkway • Cuyahoga Falls, Ohio 44223 • 330-861-1100 • 877-776-1100 • frontlineii.com • Fax: 330-861-1105 • info@frontlineii.com